



**OWNER'S (OPERATOR'S) MANUAL
AND SAFETY INSTRUCTIONS
FOR KITO MANUAL CHAIN HOIST
M3 SERIES**

ALWAYS SAVE THIS BOOK FOR FUTURE REFERENCE.



CONTENTS

1. DEFINITIONS	1
2. INTENDED PURPOSE	1
3. BEFORE USE	1
3.1 Safety summary	1
3.2 Safety instructions	2
4. MAIN SPECIFICATIONS	4
5. OPERATION	6
5.1 Intended purpose of hoist operation	6
5.2 Safety working environment	6
5.3 Operation	6
5.4 Hoist storage	6
5.5 Optional overload limiter	7
6. INSPECTION	8
6.1 Outline	8
6.2 Daily inspection	8
6.3 Periodic inspection	9
7. MAINTENANCE	14
7.1 Lubrication	14
7.2 Overhaul, assembly and adjustment	15
8. TROUBLESHOOTING	24
9. WARRANTY	25
10. PARTS LIST	26

1. DEFINITIONS

⚠ WARNING : indicates a potentially hazardous situation which, if not avoided, could result in death or serious injury.

⚠ CAUTION : indicates a potentially hazardous situation which, if not avoided, may result in minor or moderate injury. It may also be used to alert against unsafe practices.

WLL : indicates maximum mass (working load limit) which a hoist is designed to support in general service.

2. INTENDED PURPOSE

This hoist has been designed for vertically lifting and lowering loads, by hand, under normal atmospheric conditions of the work place.

3. BEFORE USE

3.1 Safety summary

Danger exists when heavy loads are transported, particularly when the equipment is not being used properly or is poorly maintained. Because accidents and serious injury could result, special safety precautions apply to the operation, maintenance and inspection of the KITO manual chain hoist M3 series.

⚠ WARNING

NEVER use a hoist for lifting, supporting or transporting people.

NEVER lift or transport loads over or near people.

NEVER lift more than WLL which is shown on the name plate.

ALWAYS let people around you know when a lift is about to begin.

ALWAYS read the operation and safety instructions.

Remember proper rigging and lifting techniques are the responsibility of the operator. Check all applicable safety codes, regulations and other applicable laws for further information about the safe use of your hoist.

More detailed safety information is contained in the following pages. For additional information, please contact KITO Corporation or your authorized KITO dealer.

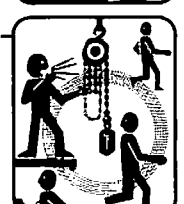
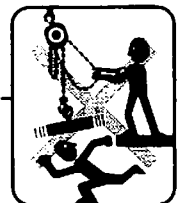
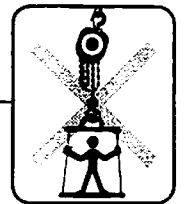

3.2 Safety instructions

▲ WARNING

3.2.1 Before use

- ALWAYS** allow the instructed (trained in safety and operation) people to operate the hoist.
- ALWAYS** check the hoist before daily use according to the "Daily inspection"(Refer to 6.2).
- ALWAYS** make sure that the chain length is long enough for the intended job.
- ALWAYS** check that the hook latches work properly and replace missing or broken hook latches (Refer to 6.3). -----
- ALWAYS** check the brake(Refer to 6.3).
- ALWAYS** oil the load chain regularly (Refer to 7.1.2).
- ALWAYS** use two hoists which each has WLL equal to or more than the load to be lifted whenever you must use two hoists to lift a load. This will provide adequate protection in the event that a sudden load shift or failure of one hoist occurs.
- NEVER** use a hoist without a hoist name plate.
- NEVER** use modified or deformed hooks.
- NEVER** use non-authentic KITO chains on the hoist.

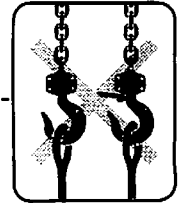

3.2.2 While operation

- ALWAYS** make sure that the load is properly seated in the hook.
- ALWAYS** tighten the slack out of the chain and sling when starting a lift to prevent a sudden loading.
- NEVER** operate a hoist unless the load is centered under the hoist.
- NEVER** use the hoist chain as a sling. -----
- NEVER** use a twisted, kinked, damaged or stretched load chain. -----
- NEVER** swing a suspended load.
- NEVER** support a load on the tip of the hook. -----
- NEVER** contact the load chain over an edge. -----
- NEVER** weld or cut a load suspended by a hoist.

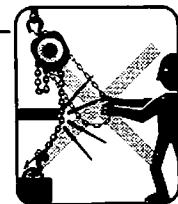
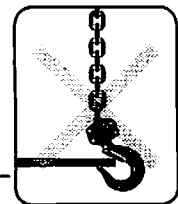
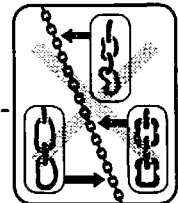
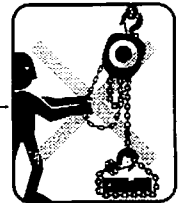

NEVER use the hoist chain as a welding electrode.

NEVER operate a hoist so far that the bottom hook touches the hoist body.

NEVER operate a hoist so far that the load chain pulls the anchorage.

NEVER operate a hoist if excessive noise occurs.

NEVER use the capsized load chain.

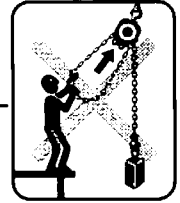
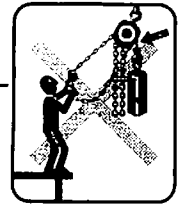

3.2.3 After operation

ALWAYS set the load down safely after carrying.

NEVER suspend a load for an extended period of time.

NEVER leave a suspended load unattended.

NEVER throw a hoist.



3.2.4 Maintenance

ALWAYS let the qualified service personnel inspect the hoist periodically (Refer to 6.3).

NEVER splice, add and weld a load chain for extension.

3.2.5 Others

ALWAYS consult the manufacturer or your dealer if you plan to use a hoist in an excessively corrosive environment (saltwater, sea air and/or acid, explosive environment or other corrosive compounds, etc.).

NEVER use a hoist which has been taken out of service until the hoist has been properly repaired or replaced.



NEVER remove or obscure the warning tags and labels.

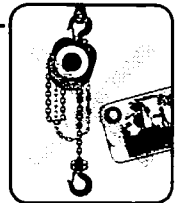

Warning tags are installed on a hand chain.

4. MAIN SPECIFICATIONS

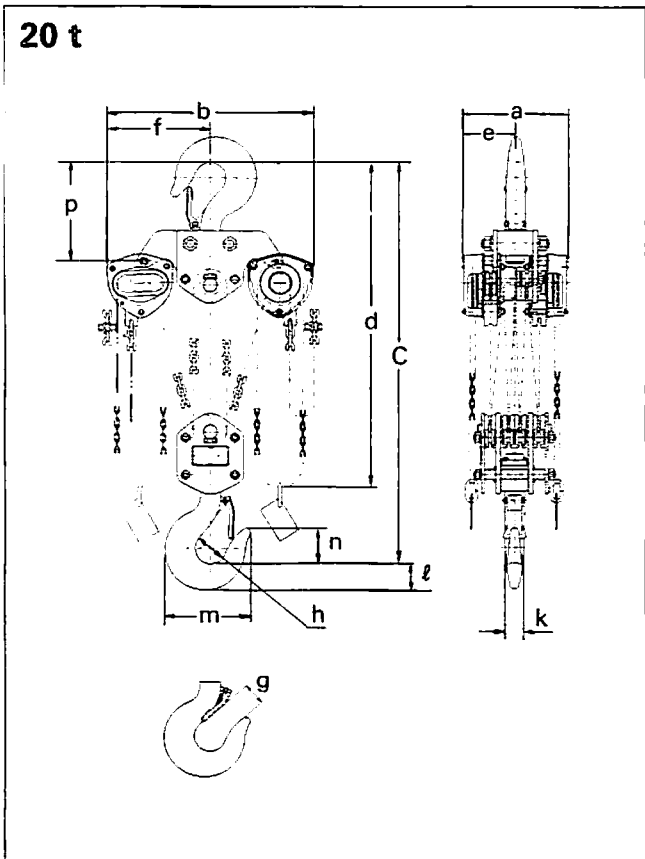
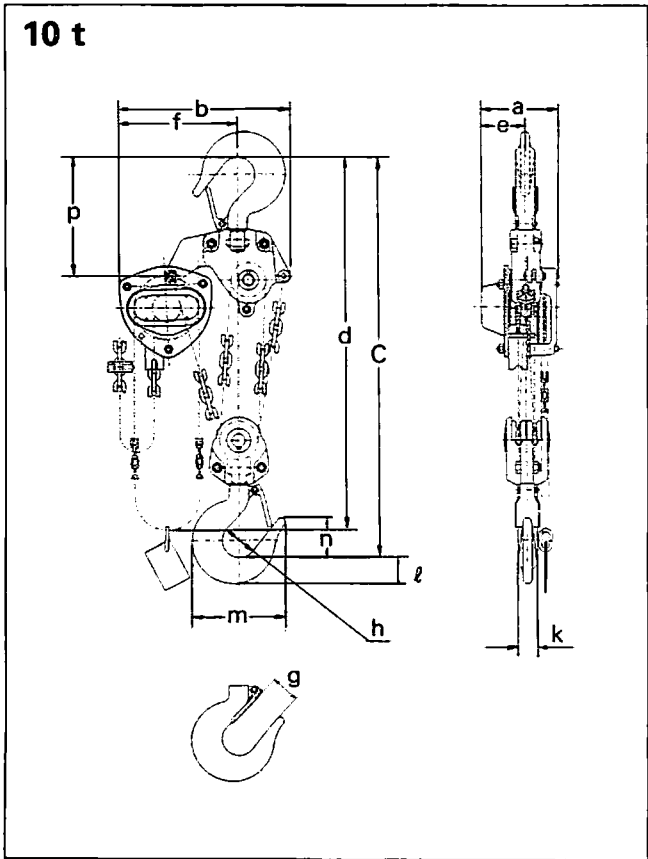
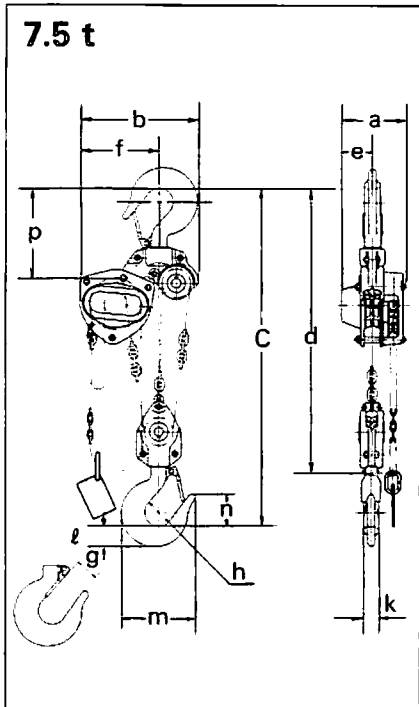
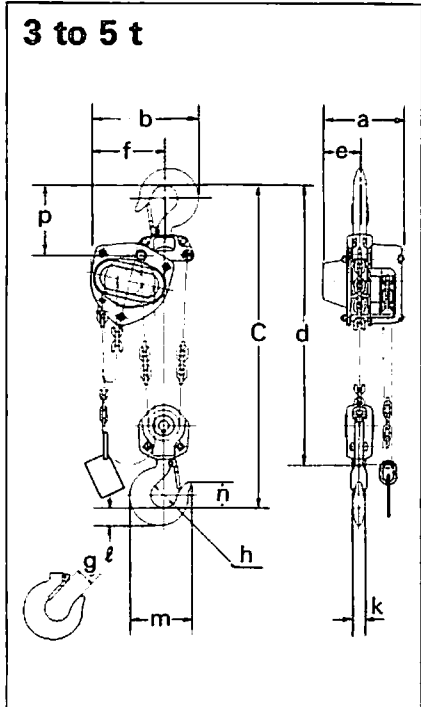
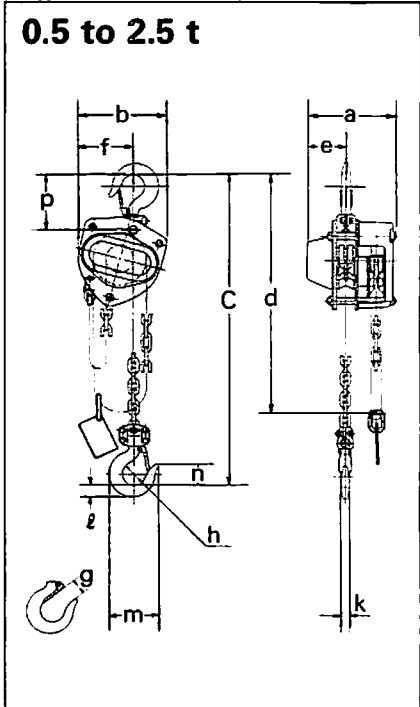

Specifications

Code	WLL (t)	Std. lift (m)	Chain pull to lift full load (N)	Chain o'hauled to lift load one meter (m)	Test load (t)	Net weight (kg)	Load chain dia. (mm) × pitch (mm)	Load chain fall (lines)	Weight for additional one meter of lift (kg)
CB005	0.5	2.5	240	25	0.75	10	5.0 × 15.1	1	1.5
CB010	1	2.5	290	43	1.5	11.5	6.3 × 19.1	1	1.8
CB015	1.5	2.5	350	57	2.36	14.5	7.1 × 21.2	1	2.1
CB020	2	3.0	360	70	3	20	8.0 × 24.2	1	2.3
CB025	2.5	3.0	330	99	3.75	27	9.0 × 27.2	1	2.7
CB030	3	3.0	360	114	4.75	24	7.1 × 21.2	2	3.2
CB050	5	3.0	340	198	7.5	41	9.0 × 27.2	2	4.4
CB075	7.5	3.5	350	297	11.25	63	9.0 × 27.2	3	6.2
CB100	10	3.5	360	396	15	83	9.0 × 27.2	4	7.9
CB150	15	3.5	370	594	22.5	155	9.0 × 27.2	6	11.4
CB200	20	3.5	360 × 2	396 × 2	30	235	9.0 × 27.2	8	15.8

Remark: Any lift of chain is available on request.

Dimensions

Code	WLL (t)	Min. distance between hooks C (mm)	a (mm)	b (mm)	d (mm)	e (mm)	f (mm)	g (mm)	h (mm)	k (mm)	ℓ (mm)	m (mm)	n (mm)	p (mm)
CB005	0.5	285	158	161	2.5	69	99	27	35.5	12.1	17	77	35	89
CB010	1	295	162	161	2.5	71	99	29	42.5	16	21.8	93	11	101
CB015	1.5	350	171	182	2.5	78	112	34	47.5	19.5	26.5	106	47	119
CB020	2	375	182	202	3	87	125	36	50	21.8	30	116	49	124
CB025	2.5	420	192	233	3	91	143	40	53	24.3	33.5	127	53	136
CB030	3	510	171	235	3.1	78	162	42.5	56	27.2	37.5	138	57	148
CB050	5	600	192	282	3.6	91	194	46.5	63	34.5	47.5	161	67.5	172
CB075	7.5	770	192	373	4.2	91	253	72.5	85	47.5	63	231	97.5	275
CB100	10	760	192	438	4.2	111	308	72.5	85	47.5	63	231	97.5	295
CB150	15	1020	268	492	4.7	119	337	80	100	60	80	275	110	320
CB200	20	1180	374	746	4.8	187	373	81	110	67	90	301	125	351

Allowable ambient conditions :

Operation temperature : - 40 °C + 60°C

Operation humidity : 100 %

Non-asbestos material :

Friction plates are made of asbestos free material.

5. OPERATION

5.1 Intended purpose of hoist operation

⚠ WARNING

This hoist has been designed for vertically lifting and lowering loads, by hand, under normal atmospheric conditions of the work place.

However, since dealing with heavy loads may involve unexpected danger, all the "Safety instructions"(Refer to 3.2) must be followed.

5.2 Safety working environment

⚠ WARNING

The operator must be aware of the following points while using the hoist.

(1) The operator must have a clear and unobstructed view of the entire travel area before operating the hoist.

When not possible, a second or more persons must serve as scouts in the nearby area.

(2) The operator must check the entire travel area is safe and secure before operating the hoist.

5.3 Operation

⚠ CAUTION

Always take care hand or clothes not to be caught in a chain, idle sheave or other moving parts.

(1) Face the hand chain wheel side of the hoist.

(2) To raise the load, pull hand chain clockwise.

(3) To lower the load, pull hand chain counterclockwise.

Remark : The clicking sound of the pawl when a load is being raised indicates normal operation.

5.4 Hoist storage

⚠ CAUTION

Observe the following points when storing the hoist.

ALWAYS store the hoist in no load condition.

ALWAYS wipe off all dirt and water.

ALWAYS oil the chain, top pin, chain pin and hook latches.

ALWAYS hang in a dry place.

ALWAYS check the hoist for abnormalities when using the hoist after a period of non-use according to the periodic inspection procedures (Refer to 6.3).

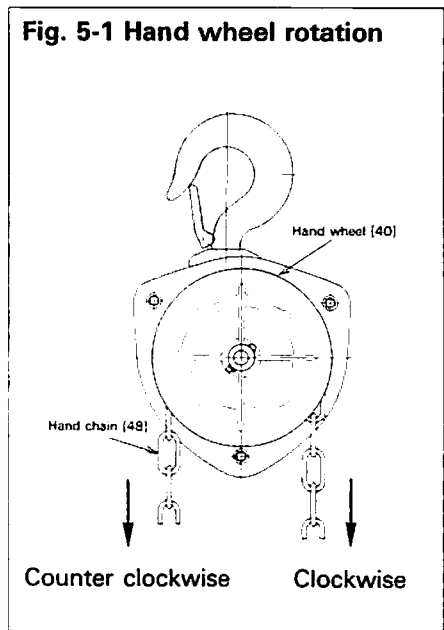

5.5 Optional overload limiter

▲ WARNING

NEVER disassemble or attempt to adjust the overload limiter assembly. Any attempt to do so will void the warranty. Contact your closest KITO dealer, if service is required.

The overload limiter device has been developed to avoid overloading. When an applied load exceeds the preset value, the hand chain wheel rotates idly. The device is friction clutch mechanism which is concentrically equipped on pinion shaft between hand chain wheel and mechanical brake.

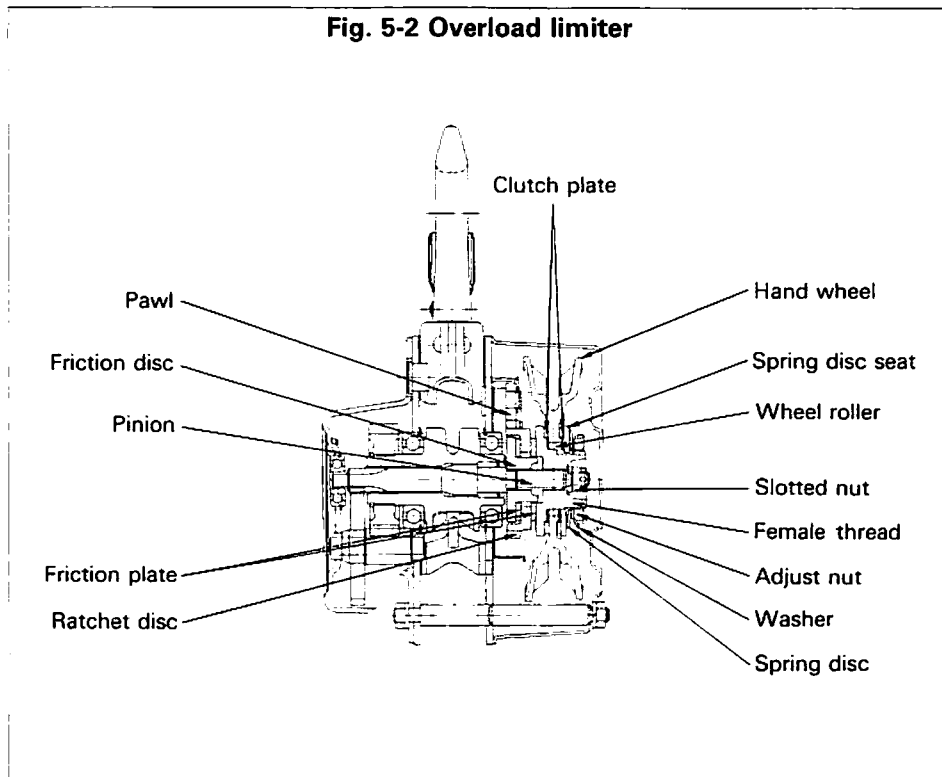

6. INSPECTION

6.1 Outline

There are two types of inspection, the daily inspection performed by the operator before using the hoist, and the more thorough periodic inspection performed by qualified service personnel who have the authority to remove the hoist from service.

6.2 Daily inspection

Before each work shift, check the following points;

Item	Inspection method	Discard limit/criteria	Remedy
1. Name plate	Check visually.	Every description should be clear and visible.	Replace the name plate.
2. Hook latches (Top/bottom)	Check visually.	The top and bottom hook latches shall be in proper condition.	Replace the latch or hook.
3. Hook	Check visually.	The openings of the top and bottom hooks shall not be too wide.	Replace the hook.
	Check visually.	No wear, deformation or damage.	Replace the hook.
	Turn the swivels by hand.	The swivels should rotate freely.	Replace the hook.
4. Load chain	Check visually.	No twisting.	Replace the deformed chain.
	Check visually.	No excessive rust or corrosion.	Replace the load chain.
5. Brake	Facing the hand chain side, operate the hoist with no load.	The pawl should emit a clear clicking sound while lifting.	Repair if impure noise or no sound.
6. Sound	Listen to the noises.	There should be no irregular noises from hand chain, load chain or gears.	Replace the noisy parts.
7. Miscellaneous	Check visually.	No missing nuts and/or split pins.	Replace the parts.

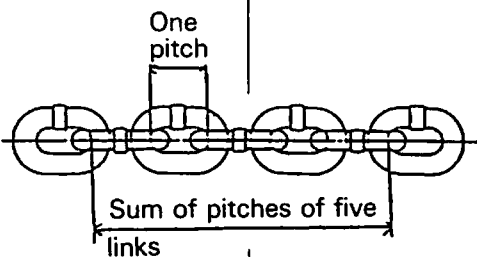
Item	Inspection method	Discard limit/criteria	Remedy																		
5. Top/ bottom fixture damage [Fittings of 1, 6, 55, 78]	Check visually.	No slack or missing rivets, nuts or bolts	Replace the hook.																		
6. Idle sheave rotation [57, 81]	Hold the load chain with both hands and turn the idle sheave by moving the chain up and down.	Smooth rotation	Overhaul.																		
7. Hook latch [2, 7, 56, 80]	Check visually.	Proper positioning and smooth working	Replace the hook latch or hook.																		
Load chain [47, 110]																					
1. Wear	Measure with slide calipers.	Measure the sum of pitches of five chain links and check that the maximum length does not exceed value shown in table below.	Replace the chain.																		
		<table border="1"> <thead> <tr> <th>WLL (t)</th> <th>Sum of pitches of five links (mm)</th> <th>Discard limit (mm)</th> </tr> </thead> <tbody> <tr> <td>0.5</td> <td>75.5</td> <td>77.7</td> </tr> <tr> <td>1</td> <td>95.5</td> <td>98.3</td> </tr> <tr> <td>1.5, 3</td> <td>106.0</td> <td>109.1</td> </tr> <tr> <td>2</td> <td>121.0</td> <td>124.6</td> </tr> <tr> <td>2.5, 5, 7.5, 10, 15, 20</td> <td>136.0</td> <td>140.0</td> </tr> </tbody> </table>	WLL (t)	Sum of pitches of five links (mm)	Discard limit (mm)	0.5	75.5	77.7	1	95.5	98.3	1.5, 3	106.0	109.1	2	121.0	124.6	2.5, 5, 7.5, 10, 15, 20	136.0	140.0	
WLL (t)	Sum of pitches of five links (mm)	Discard limit (mm)																			
0.5	75.5	77.7																			
1	95.5	98.3																			
1.5, 3	106.0	109.1																			
2	121.0	124.6																			
2.5, 5, 7.5, 10, 15, 20	136.0	140.0																			
2. Rust, flaw, deformation	Check visually. Check visually.	No obvious rust (Apply oil as necessary.) No twist or harmful flaw.	Remove rust. Replace the load chain.																		
Hook yoke (Top set [1, 54] Bottom set [6, 77]) Joint of top/bottom fixtures with top pin [4] and chain pin [8, 106]	Measure hole diameter of joint area in two directions at right angle.	Deformation not permitted (if each measured value differs more than 0.5mm).	Replace the part.																		

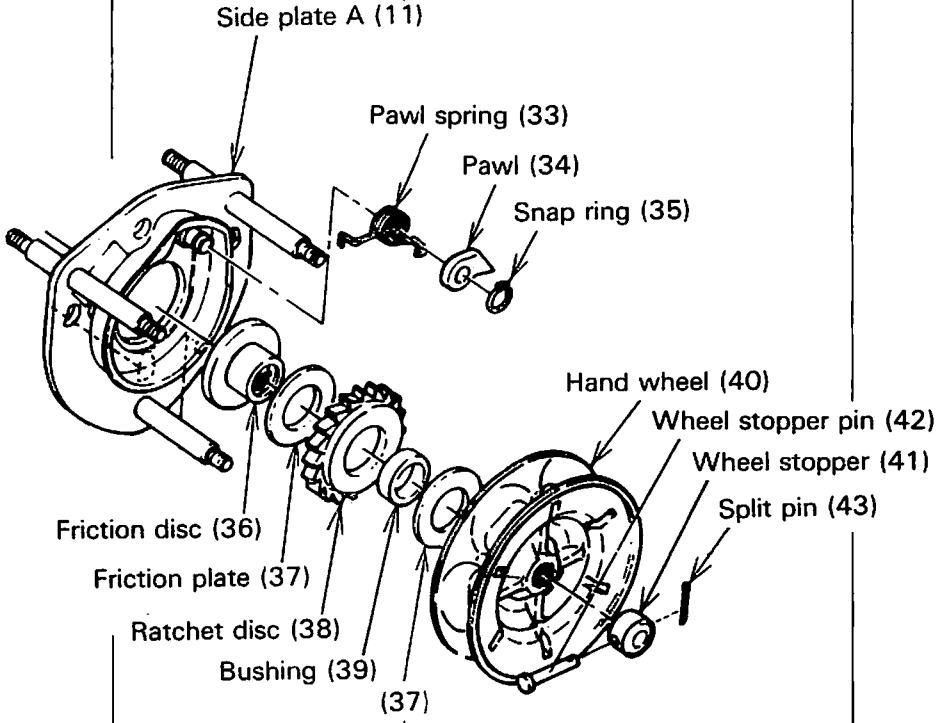
Item	Inspection method	Discard limit/criteria	Remedy
<p>Function</p> <p>1. Lifting and lowering</p> <p>2. Brake</p>	<p>Lift and lower a light load.</p> <p>Lift and lower a light load.</p>	<p>No abnormal difficulty in lifting or lowering.</p> <p>Confirm that none of the problems listed below occur during lifting and lowering:</p> <p>(1) Lifting impossible.</p> <p>(2) Load falls when the operator removes his hands.</p> <p>(3) Load falls during unwinding.</p> <p>(4) Load slips down slowly.</p>	<p>Overhaul and service.</p> <p>Overhaul and service.</p>
<p>Brake (Inside mechanism)</p>	<p>Overhaul and check.</p>		<p>1. Flaw on brake surface [37, 38, 39] Check visually. No flaw due to scratching or gouging by foreign matter. Replace the part.</p> <p>2. Flaw on friction disc [36] Check visually. No flaw due to scratching or gouging by foreign matter. Replace the part.</p> <p>3. Wear on friction plate [37] Measure with slide calipers. Retain uniform thickness and friction plates shall not be worn more than 0.5 mm. For all types; Normal thickness: 3mm Discard limit: 2.5mm Replace the part.</p>

Item	Inspection method	Discard limit/criteria	Remedy									
4. Flatness of friction plate [37]	Check clearance with straight gauge.	Clearance shall be uniform. Internal part shall not be thicker than external part.	Replace the part.									
5. Wear and oil of bushing [39]	Check radial thickness (t) with slide calipers and oil existence.	Radial thickness (t) shall be uniform. Oil shall be contained. Refer to table below.	Replace the part.									
<table border="1"> <thead> <tr> <th>WLL (t)</th> <th>Normal thickness:t(mm)</th> <th>Discard limit (mm)</th> </tr> </thead> <tbody> <tr> <td>0.5, 1, 1.5, 3</td> <td>3</td> <td>2</td> </tr> <tr> <td>2, 2.5, 5, 7.5, 10, 15, 20</td> <td>4</td> <td>3</td> </tr> </tbody> </table>				WLL (t)	Normal thickness:t(mm)	Discard limit (mm)	0.5, 1, 1.5, 3	3	2	2, 2.5, 5, 7.5, 10, 15, 20	4	3
WLL (t)	Normal thickness:t(mm)	Discard limit (mm)										
0.5, 1, 1.5, 3	3	2										
2, 2.5, 5, 7.5, 10, 15, 20	4	3										
6. Wear and rust of ratchet disc [38]	Check visually.	The tooth wear shall not be more than 1.5mm.	Replace the part.									
	Check visually.	No rust	Replace the part.									
Lifting system												
1. Wear and deformation of load sheave [14]	Check visually.	No large wear, no deformation or no burr due to load chain contact is permitted on the surface of load chain pocket.	Replace the part.									
2. Wear and flaw of gear [25, 27]	Check visually.	Teeth shall be free from large wear or flaw.	Replace the part.									

Item	Inspection method	Discard limit/criteria	Remedy
3. Wear and deformation of hand wheel [40]	Check visually. Check visually.	No large wear or no deformation on the surface of hand chain pocket Turn and check if it touches the cover.	Replace the part. Replace the part.
Side plate [11, 13] 1. Deformation of top pin hole 2. Slack stay bolt restraint	Check visually. Tap.	Hole shall not be oval. No slack is permitted.	Replace the part. Replace the side plate.
Miscellaneous 1. Deformation of stripper [21] 2. Flaw on guide roller [20]	Check visually. Check visually. Check visually.	No large crush or damage on stripper tip is permitted. Shall turn lightly. No large deformation.	Replace the part. Replace the part. Replace the part.

7. MAINTENANCE

WARNING

- (1) **NEVER** perform maintenance on the hoist while it is supporting a load.
- (2) Before performing maintenance, attach the tag:
[“DANGER” : **NEVER** OPERATE EQUIPMENT BEING REPAIRED.]
- (3) Only allow qualified service personnel to perform maintenance.
- (4) After performing any maintenance on the hoist, **ALWAYS** test to WLL before returning to service.

CAUTION

ALWAYS take care hand or clothes not to be caught in a chain, idle sheave or other moving parts.

7.1 Lubrication

7.1.1 Applying grease to gears

Unscrew nuts (31), on the opposite side of hand chain wheel, and remove spring washers (32) and gear case (29). Remove old grease and replace with new grease (standard grease⁽¹⁾), at annual inspection.

Temperature range of standard grease is -40°C to $+60^{\circ}\text{C}$.

If the hoist is used at temperature below -40°C or above $+60^{\circ}\text{C}$, consult KITO or authorized KITO dealer since some parts shall be changed.

Note : ⁽¹⁾ Recommended brand: SHELL Albania # 3 or calcium soap grease equivalent of NLGI (National Lubricating Grease Institute)/ # 3

7.1.2 Load chain

WARNING

Failure to maintain clean and well lubricated load chain will void the manufacturer's warranty.

ALWAYS lubricate load chain weekly, or more frequently, depending on severity of service.

ALWAYS lubricate more frequently than normal in a corrosive environment.⁽²⁾

ALWAYS use machine oil equivalent to ISO VG46 or 68.

Note : ⁽²⁾ KITO has a corrosion-resistant chain as an option.

For information on KITO's regular and corrosion-resistant chain, please ask KITO or authorized KITO dealer.

7.2 Overhaul, assembly and adjustment

7.2.1 Overhaul

Figures in parentheses are Fig. No. in "PARTS LIST". (Refer to page 27 to 32.)

Overhaul procedures	Remarks
<ol style="list-style-type: none"> 1. Put a hoist with wheel cover side up. 2. Unscrew three nuts [45] (with the spring washers [46])fixing the wheel cover [44] and remove the wheel cover from the side plate A [11]. 3. Remove the hand chain [48] from the hand wheel [40]. 4. Pull out the split pin [43] from the wheel stopper pin [42] and remove the wheel stopper pin and the wheel stopper [41] from the pinion [17]. 5. Remove the hand wheel [40] from the pinion [17] by turning the hand wheel counterclockwise. 6. Remove two friction plates [37], the ratchet disc [38] and the bushing [39] from the friction disc [36]. 7. Unscrew the friction disc [36] from the pinion [17] by turning counterclockwise holding the end of the pinion with fingers. 8. Remove the snap ring [35] from the pawl pin (on the side plate A) and then remove the pawl [34] and pawl spring A and B [33]. 9. <For 7.5t and smaller types> Pull the split pin [24] out from the stopper pin [23] and remove the load chain [47] and the stopper pin from the anchorage [22]. <For 10t and larger types> Pull the split pin [52] out from the end pin [51] and remove the load chain [47] and the end pin. Unscrew two socket bolts (with the spring washers) fixing the stoppers [114] and remove the stoppers. 10. Remove the load chain [47] from the load sheave [14] by pulling the load chain toward the bottom hook. 11. Remove the split pin [5] from the top pin [4], then remove the top pin and the top hook [1] from the side plate A [11] and B [13]. 12. Put a hoist with gear case side (or name plate side) up. 	<p>If the hand wheel is too tight to turn by hand, put the hand chain on the hand wheel back again and pull it down hard. It will release the brake.</p>

Overhaul procedures	Remarks
<p>13. Unscrew three nuts [31] (with the spring washers [32]) fixing the gear case [29], remove the gear case from the side plate B [13], and take the ball bearings [28] out from the gear case.</p> <p>14. Remove two gear # 2 [27] (0.5t has one) from the side plate B [13].</p> <p>15. Remove the snap ring [26] from the load sheave [14], then the load gear [25] from the load sheave.</p> <p>16. Remove the side plate B [13] from the side plate A [11] and then take the ball bearing [16] out from the side plate B.</p> <p>17. Remove the guide rollers [20], load sheave (attached to the pinion [17]), stripper [21] and anchorage [22] (For 10t and larger types: cross guide [53]) from the side plate A [11], then remove the ball bearing [15] from the side plate A.</p> <p>18. Remove the snap ring [19] in the load sheave [14].</p> <p>19. Remove the pinion [17] and the roller bearing [18] from the load sheave [14].</p> <p>20. Pull the split pin [10] out from the slotted nut [9] and remove the slotted nut and chain pin from the bottom hook [6].</p>	<p>Hold the load sheave with a hand and remove the bearing by tapping the pinion with a wooden hammer.</p>

7.2.2 Assembly and adjustment

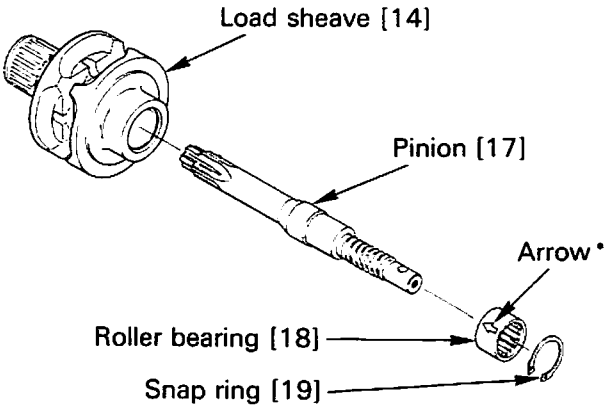
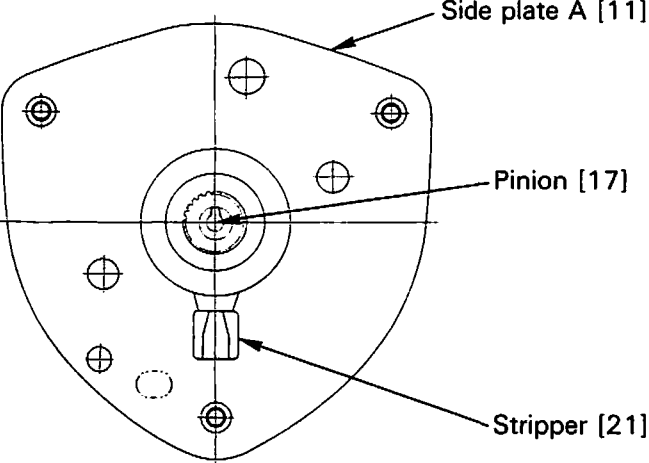
Assembly procedures	Remarks
<p>1. Apply grease to the rollers of the roller bearing [18] and insert the pinion [17] (from the side of the brake screw) into the roller bearing and insert them together into the load sheave [14]. Fix them with a snap ring [19].</p> 	<p>The arrow* direction on the outer side of the roller bearing shall be faced to pinion gear side. When inserting, use a screwdriver on the bearing and tap it with a wooden hammer. Always make sure that the snap ring is correctly seated.</p>
<p>2. Put the side plate A [11] with a brake cover side down and insert the ball bearing [15] (with a snap ring side up) into the side plate A. Grease the balls of ball bearing shown in the side plate A.</p> <p>3. Insert the load sheave [14] with a part of involute serration side (pinion gear side) up into the ball bearing [15]. The stripper [21] must be put as well.</p>	
	
<p>4. <For 7.5t and smaller types> Put the guide rollers [20] and the anchorage [22] on the side plate A [11]. <For 10t and larger types> Put the guide rollers [20] and the cross guide [53] on the side plate A [11].</p>	<p>Put the cross guide so that the longer arm fits to the side plate A.</p>

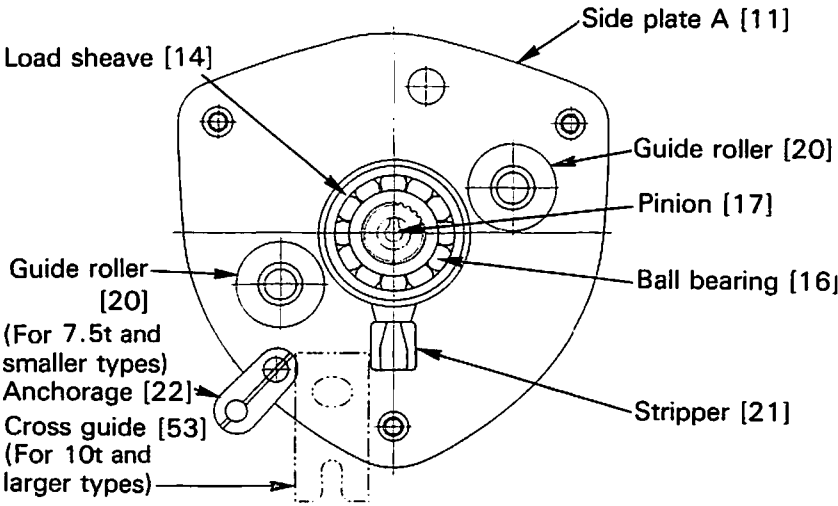
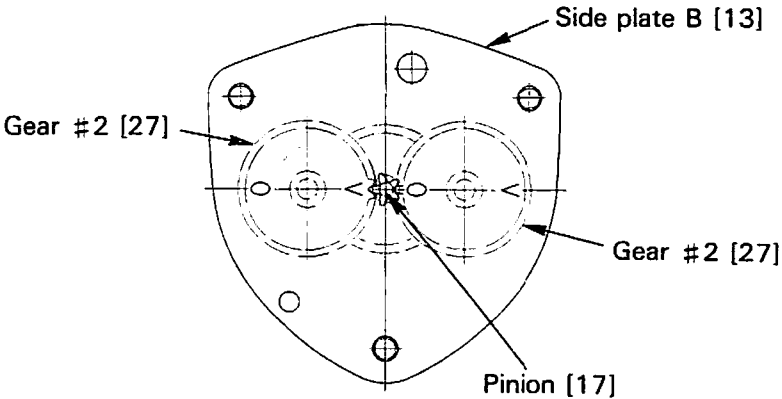
Assembly procedures	Remarks
<p>5. Grease the balls of the ball bearing [16]. Insert it with the snap ring side down to the shaft of the load sheave [14].</p> 	<p>As for the ball bearing of the load sheave, make sure that the snap ring is placed on the side of the load sheave where the load chain reeves.</p>
<p>6. Join the side palte B [13] to the side plate A [11].</p>	<p>In case it is difficult to join the two, tap it with a wooden hammer. Be careful not to let the stripper, guide roller, and anchorage fall down.</p>
<p>7. Mesh the load gear [25] with the involute serration of the load sheave [14] and fix it with a snap ring [26]</p>	<p>ALWAYS make sure the snap ring is completely set at the bottom of the groove.</p>
<p>8. Grease the two gear #2 [27], the load gear [25] and the gear of the pinion [17]. Put them in the plain bearing (bearing A) of the side plate B [13]. Letters O and V on the gears must face to each other as shown in the below figure. Do not forget to apply grease to the boss on the both sides of the gear #2.</p>	<p>It is not necessary to adjust the letters in case of the 0.5t type, for it has only one gear #2.</p>
	

Assembly procedures	Remarks
<p>9. Grease the balls of the ball bearing [28] and insert it with the snap ring down into the end of the pinion [17] shaft.</p> <p>10. Join the gear case [29] to the side plate B [13] and fix them with the three spring washers [32] and nuts [31].</p> <p>11. Place the top hook [1] between the side plate A [11] and B [13]. Then insert top pin [4], and fix it with the split pin [5].</p>	<p>ALWAYS bend the split pin securely after inserting it into the top pin.</p>
<p>12. Place the hand wheel [40] side upward.</p>	

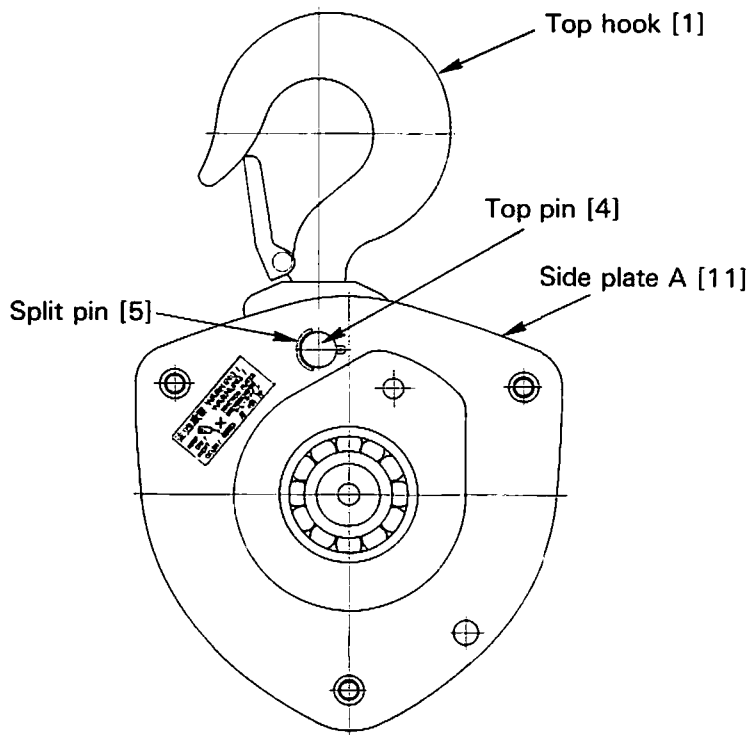

Assembly procedures	Remarks
<p>13. Reeve the load chain [47] turning the pinion [17] shaft clockwise through the space between the left (bottom hook side) guide roller [20] and the load sheave [14].</p> <p>For 10t or larger types, pass the no load end of the chain through the cross guide [53].</p>	<p>Put the welded part of the standing chain link outward and reeve it through the load sheave. Pull it out between the right guide roller (no load side) and the load sheave.</p> <p>It is recommended for this process to position the unit so that the side plate A [11] faces left and the side plate B [13] faces right.</p>

Assembly procedures	Remarks
---------------------	---------

14. <For 7.5t and smaller types>

Pull the end of the load chain [47] out between the right guide roller [20] and the load sheave [14] (no load side) and insert it to the anchorage [22]. Insert the stopper pin [23] and fix it with a split pin [24].

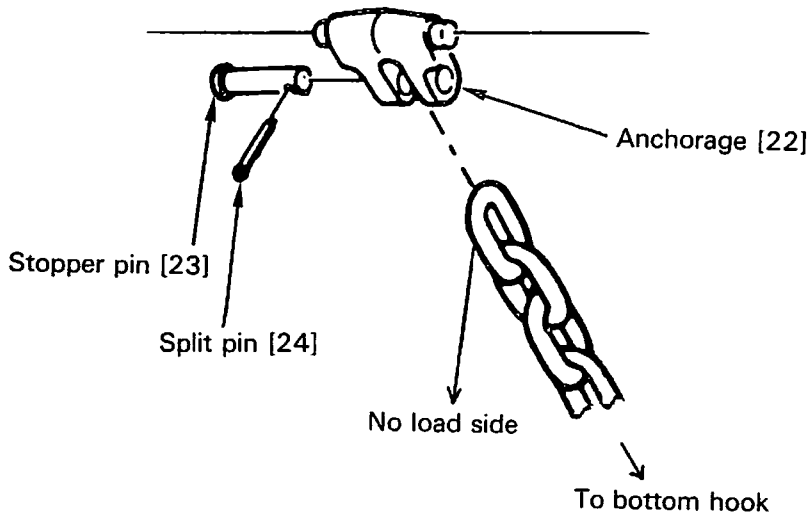

Make sure the load chain is not twisted and the split pin in the stopper pin is bent thoroughly.

<For 10t and larger types>

Connect the no load end of the load chain [47] to end pin [51] which is to be inserted from gear case [29] side. Use a split pin [52] to secure the end pin. Fix stoppers [114] to the ninth link from the no load end of the load chain by assembling with socket bolts and spring washers.

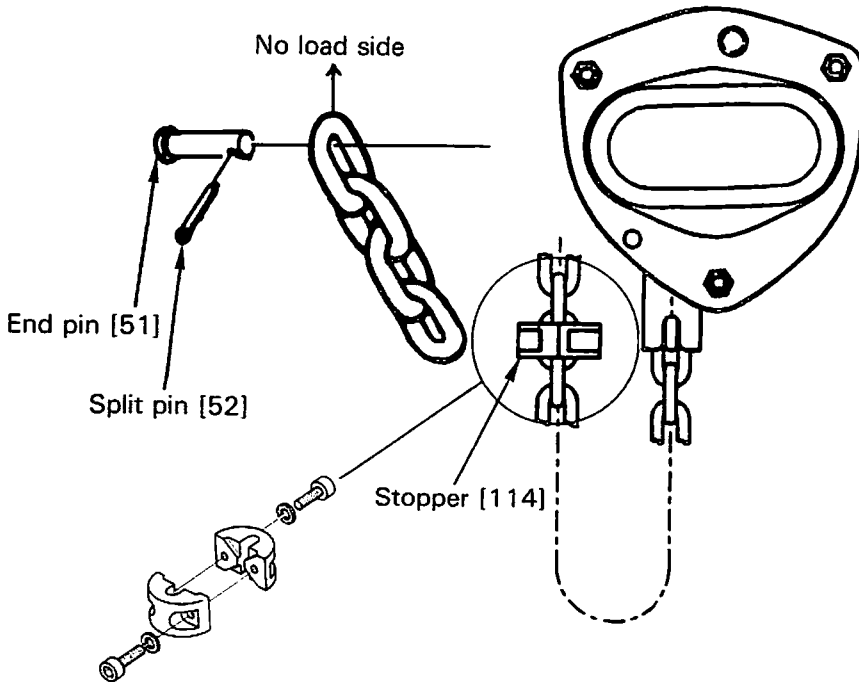

Screwed hole side of one stopper shall face to non-screwed hole side of the other stopper. Socket bolt shall be inserted from the non-screwed side.

Assembly procedures	Remarks
<p>15. Apply machine oil to the pawl pin (in side plate A [11]) and join the pawl spring A, B [33] and the pawl [34] respectively to it. Fix them with a snap ring [35].</p> <p>16. Put the friction disc [36] to the pinion [17] shaft (while turning the pawl [34] counterclockwise).</p> <p>17. Wipe out any dirt on the friction disc [36], friction plates [37] and both sides of the ratchet disc [38] and check if the oil of the bushing [39] (bushing with containing oil) is applied enough. Then place the friction plate, bushing, ratchet disc and friction plate respectively on the friction disc. (Make sure that the pawl meshes with the ratchet disc properly)</p>	<p>Make sure the pawl spring is touching the pawl and the snap ring is completely set at the bottom of the groove.</p> <p>⚠ WARNING</p> <p>NEVER apply oil since the brake is 'dry-type' . Wipe out thoroughly any oil and dirt on the brake. The gear of the ratchet disc should point at the pawl. Otherwise, the hand wheel cannot be assembled later. However, in case the bushing does not have oil inside, soak it in tarbin oil for a day. Install it in without wiping the oil. Make sure that the pawl meshes with the ratchet disc properly.</p>
<p>The diagram illustrates the internal components of a hand wheel assembly. At the center is a pinion shaft. A ratchet disc [38] is mounted on this shaft, featuring a series of teeth. A pawl [34] is positioned to engage with these teeth, held in place by a pawl spring [33]. A snap ring [35] is used to secure the pawl assembly. A friction disc [36] is also mounted on the shaft, with friction plates [37] and a bushing [39] on either side. The entire assembly is housed in a side plate A [11].</p>	<p>18. Wipe out the dirt of the hand wheel [40] and apply machine oil to the threaded part of it. Screw it in the pinion [17] shaft all the way down.</p> <p>19. Place the wheel stopper [41] on the head of the pinion [17], insert the wheel stopper pin [42] and fix it with a split pin [43].</p> <p>ALWAYS bend the split pin securely after inserting into the wheel stopper pin.</p>

Assembly procedures	Remarks
---------------------	---------

20. Put the hand chain [48] around the hand wheel [40].

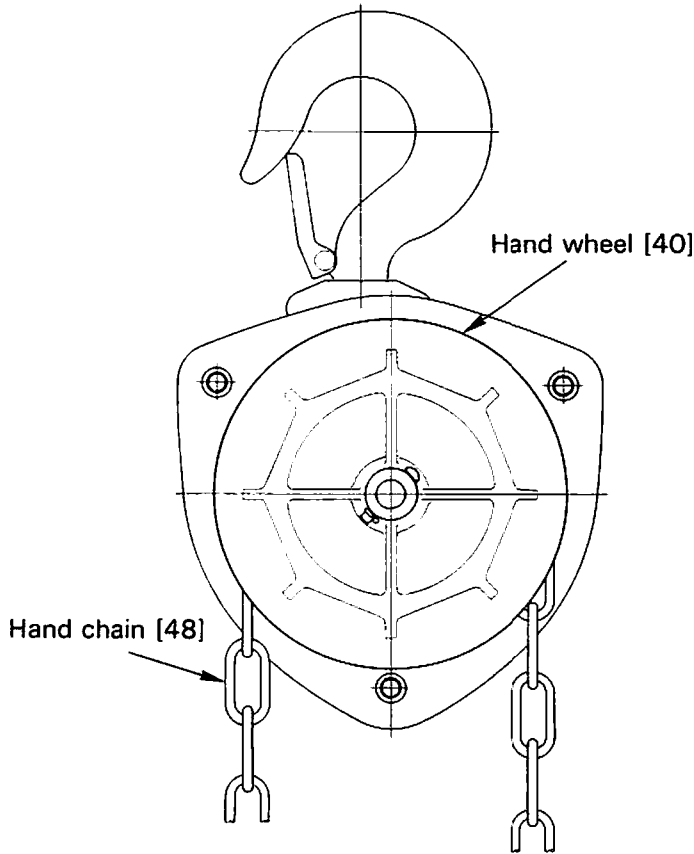

21. Join the wheel cover [44] to the side plate A [11] and fix them with the spring washers [45] and the nuts [46].

22. Insert the other end of the load chain [47] to the bottom hook [6] and fix them with the chain pin [8], slotted nut [9] and split pin [10].

ALWAYS bend the split pin securely.

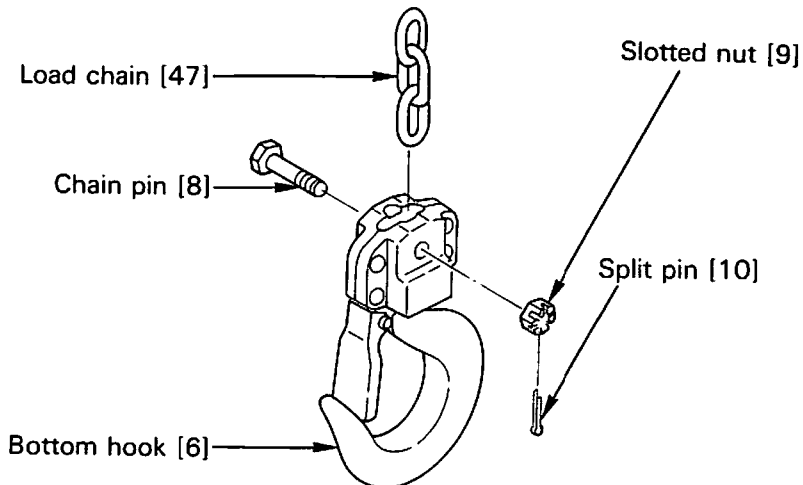

8. TROUBLESHOOTING

Situation	Cause	Explanation	Remedy
The pawl makes the proper clicking sound but fails to lift the load.	Worn friction plates	When used at high frequency without performing maintenance regularly, the friction plates will wear down. This will create gaps between the friction disc, bushing and hand wheel, and cause the brake to slip.	Disassemble and replace the friction plates and bushing.
The pawl produces absolutely no sound and fails to lift the load.	The pawl has been improperly assembled.	If the pawl is assembled facing the other way, or otherwise assembled incorrectly, it will not cleanly mesh with the ratchet disc.	Disassemble and then reassemble parts correctly.
	The pawl is not moving smoothly.	Unless maintenance is performed regularly, dirt will adhere to the grease on the pawl and pawl shaft. Movement will become sluggish and the pawl will remain stuck in the kicked out position.	Same as above
The chain is tight when lifting, even without a load. (A squeaking noise can be heard at times.)	Worn gear teeth	Unless maintenance is performed regularly, greased parts will dry, resulting in wear and damage, and improper meshing of gears.	Disassemble and replace the pinion, gear #2, load gear, gear case, side plate B and ball bearing.
	Worn or damaged bearing		
Improper lowering or the chain is extremely tight when lowering.	The brake is too tight.	Due to shock during work, or because the load was left suspended for a long period of time, the brake tightened.	Free the brake forcibly by jerking the hand chain.
	The brake is rusted.	Unless maintenance is performed regularly, rusting will occur.	Disassemble and replace parts where necessary.
The hoist drops the load the instant lowering is started.	The braking surface is dirty.	During assembly, the braking surface must be wiped cleaned of dirt.	Disassemble and then reassemble parts correctly.
	The braking surface is oily.	The braking surface must not be allowed to become soiled with grease or machine oil because it is a dry-type brake.	Disassemble and then reassemble parts. Do not oil or grease the braking surface or friction plates.
Load slipping	The braking surface is oily.	Same as above	Same as above
	The braking surface is dirty.	During assembly, the braking surface must be wiped cleaned of dirt.	Disassemble and then reassemble parts correctly.

9. WARRANTY

KITO Corporation ("KITO") extends the following warranty to the original purchaser ("Purchaser") of new products manufactured by "KITO" (KITO's Products).

- (1) "KITO" warrants that KITO's Products, when shipped, shall be free from defects in workmanship and/or materials under normal use and service and "KITO" shall, at the election of "KITO", repair or replace free of charge any parts or items which are proven to have said defects, provided that all claims for defects under this warranty shall be made in writing immediately upon discovery and, in any event, within one (1) year from the date of purchase of KITO's Products by "Purchaser" and provided, further, that defective parts or items shall be kept for examination by "KITO" or its authorized agents or returned to KITO's factory or authorized service center upon request by "KITO".
- (2) "KITO" does not warrant components of products provided by other manufacturers. However to the extent possible, "KITO" will assign to "Purchaser" applicable warranties of such other manufacturers.
- (3) Except for the repair or replacement mentioned in (1) above which is "KITO"'s sole liability and purchaser's exclusive remedy under this warranty, "KITO" shall not be responsible for any other claims arising out of the purchase and use of KITO's Products, regardless of whether "Purchaser"'s claims are based on breach of contract, tort or other theories, including claims for any damages whether direct, indirect, incidental or consequential.
- (4) This warranty is conditional upon the installation, maintenance and use of KITO's Products pursuant to the product manuals prepared in accordance with content instructions by "KITO". This warranty shall not apply to KITO's Products which have been subject to negligence, misuse, abuse, misapplication or any improper use or combination or improper fittings, alignment or maintenance.
- (5) "KITO" shall not be responsible for any loss or damage caused by transportation, prolonged or improper storage or normal wear and tear of KITO's Products or for loss of operating time.
- (6) This warranty shall not apply to KITO's Products which have been fitted with or repaired with parts, components or items not supplied or approved by "KITO" or which have been modified or altered.

THIS WARRANTY IS IN LIEU OF ALL OTHER WARRANTIES, EXPRESS OR IMPLIED, INCLUDING BUT NOT LIMITED TO ANY WARRANTY OF MERCHANTABILITY OR OF FITNESS FOR A PARTICULAR PURPOSE.

11. PARTS LIST

When ordering replacement parts, please specify WLL, Fig. No., part No., part name and quantity.

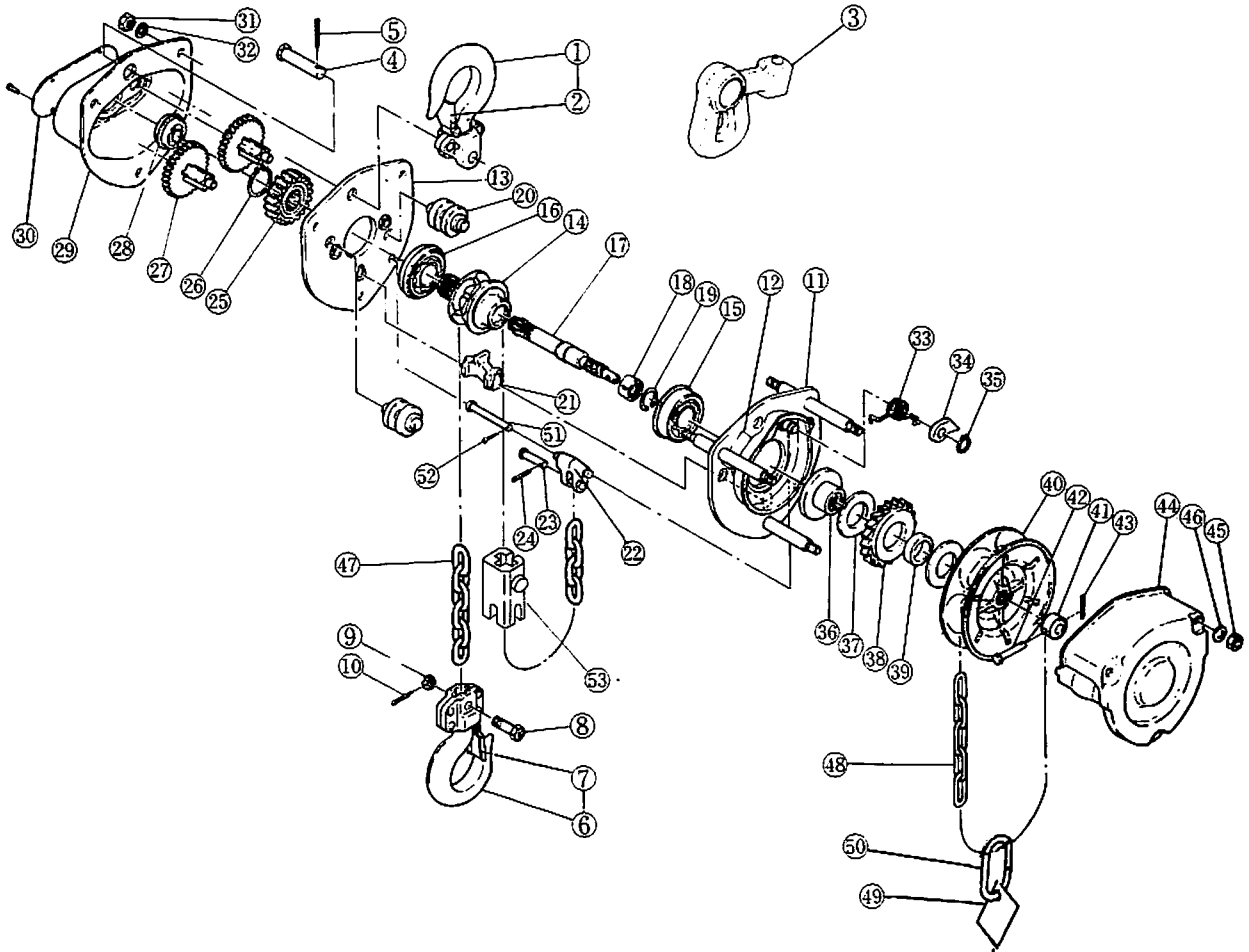

Additional parts for 3t and larger types

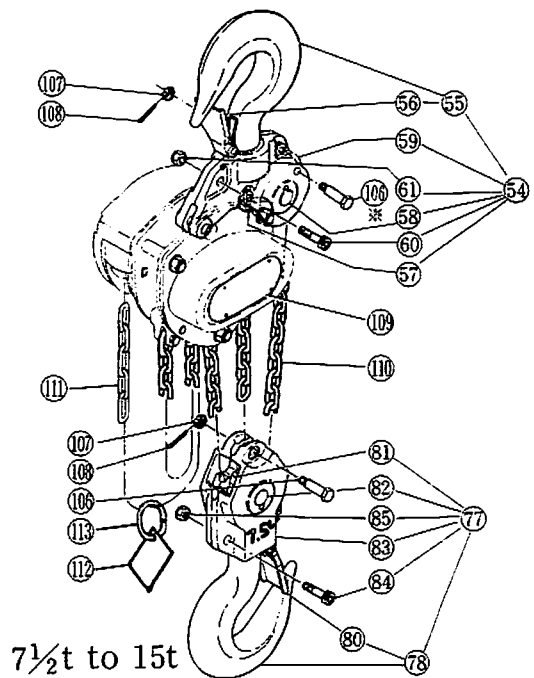
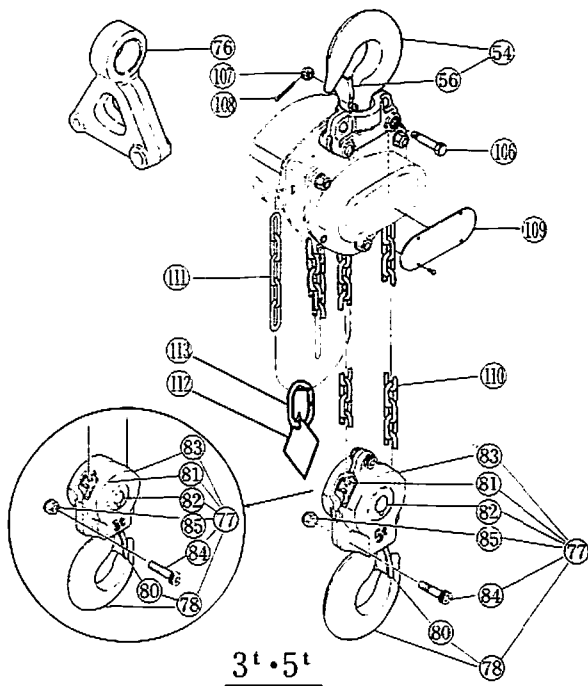

※ The Chain pin of 10t model is located on top voke to connect the Load chain.

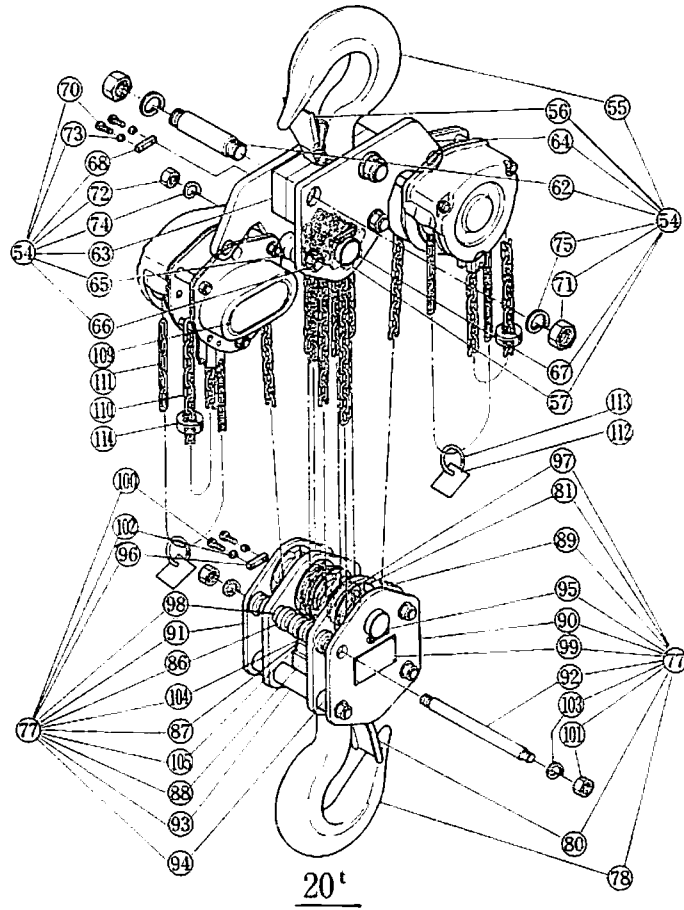

Fig. No.	Part No.	Part name	No. per hoist	WLL(t)											
				0.5	1	1.5	3	2	2.5	5	7.5	10	15	20	
①	M3-001A	Top hook set	1												
2	M3-072	Hook latch assembly	1												
③	*	Suspender for TSP005	1												
	*	Suspender for TSG010	1												
	*	Suspender	1												
④	M3-163	Top pin	1												
⑤	M3-198	Split pin	1												
⑥	M3-021A	Bottom hook set	1												
7	M3-072	Hook latch assembly	1												
⑧	M3-041	Chain pin	1												
⑨	M3-049	Slotted nut	1												
⑩	M3-096	Split pin	1												
⑪	M3-101 ⁽¹⁾	Side plate A assembly	1												
12	M3-806	Name plate F	1												
⑬	M3-102 ⁽¹⁾	Side plate B assembly	1												
⑭	M3-116	Load sheave	1												
⑮	M3-140	Ball bearing	1												
⑯	M3-145	Ball bearing	1												
⑰	M3-111 ⁽¹⁾	Pinion	1												

* see trolley parts lists.

Fig. No.	Part No.	Part name	No. per hoist	WLL(t)											
				0.5	1	1.5	3	2	2.5	5	7.5	10	15	20	
18	M3-130	Roller bearing	1												
19	M3-118	Snap ring	1												
20	M3-161	Guide roller	2												
21	M3-162	Stripper	1												
22	M3-176	Stopper	1												
23	M3-177	Stopper pin	1												
24	M3-196	Split pin	1												
25	M3-114	Load gear	1												
26	M3-117	Snap ring	1												
27	M3-112 ⁽¹⁾	Gear # 2 assembly	⁽³⁾	1	2	2		2					2		
28	M3-135	Ball bearing	1												
29	M3-103	Gear case assembly	1												
30	M3-800 ⁽¹⁾	Name plate B with rivets	1												
31	M3-181	Nut	3												
32	M3-186	Spring washer	3												
33	M3-179	Pawl spring A ⁽²⁾	1												
	M3-180	Pawl spring B ⁽²⁾	1												
34	M3-155	Pawl	1												
35	M3-157	Snap ring	1												
36	M3-153 ⁽¹⁾	Friction disc	1												
37	M3-151 ⁽¹⁾	Friction plate	2												
38	M3-152 ⁽¹⁾	Ratchet disc	1												
39	M3-154 ⁽¹⁾	Bushing	1												
40	M3-115 ⁽¹⁾	Hand wheel	1												
41	M3-159	Wheel stopper	1												
42	M3-167	Wheel stopper pin	1												
43	M3-199	Split pin	1												
44	M3-171	Wheel cover assembly	1												
45	M3-182	Nut	3												
46	M3-187	Spring washer	3												
47	M3-841	Load chain	1												
48	M3-842	Hand chain	1												
49	M3-931	Warning tag	1												
50	M3-045	Chain stopper link	1												
51	M3-164	End pin	1												
52	M3-197	Split pin	1												
53	M3-176	Cross guide	1												

Note : (1) When ordering replacement part, use the symbol M3B in place of M3 for 2.5t, 5t and larger types, because there are no interchangeability.

(2) Pawl spring A and B must be used as a set.

(3) Each number in "WLL" columns is No. per hoist.

Remark : Every part quantity becomes twice of the number in the column "No. per hoist" for 20t hoist.

Fig. No.	Part No.	Part name	No. per hoist	WLL(t)					
				3	5	7.5	10	15	20
④	M3-001A	Top hook set	1						
55	M3-001	Top hook	1						
	M3-001	Top hook assembly	1						
56	M3-072	Hook latch assembly	1						
57	M3-051	Idle sheave assembly	⁽³⁾			1	1	2	3
58	M3-053	Shaft assembly	1						
59A	M3-011	Top yoke A	1						
	M3-016	Top yoke A	1						
59B	M3-012	Top yoke B	1						
	M3-017	Top yoke B	1						
60	M3-081	Socket bolt	⁽³⁾			3	1		
61	M3-082	Lever nut	⁽³⁾			3	1		
—	M3-086	Socket bolt	2						
—	M3-087	U nut	2						
62	M3-010	Top suspension shaft	2						
63	M3-011	Top yoke	2						
64	M3-012	Top plate A assembly	⁽³⁾					1	2
—	M3-014	Top plate B	1						
65	M3-018	Guide	⁽³⁾					4	6
66	M3-019	Stay bolt	2						
—	M3-043	Top plate	1						
67	M3-053	Top shaft	1						
68	M2-056	Key plate	2						
—	M3-066	Collar	2						
70	M3-083	Socket bolt	4						
71	M3-084	Nut	4						
72	M3-085	Nut	4						
73	M3-087	Spring washer	4						
74	M3-088	Spring washer	4						
75	M3-089	Spring washer	4						
⑥	*	Suspender for TSP & TSG	1						
⑦	M3-021A	Bottom hook set	1						
78	M3-021	Bottom hook	1						
	M3-021	Bottom hook assembly	1						
80	M3-072	Hook latch assembly	1						
81	M3-051	Idle sheave assembly	⁽³⁾	1	1				
	M3-052	Idle sheave assembly	2						
82	M3-053	Shaft assembly	1						
	M3-054	Bottom shaft assembly	1						
83	M3-031	Bottom yoke	2						
84	M3-081	Socket bolt	⁽³⁾	2	3	2			

* see trolley parts lists

Fig. No.	Part No.	Part name	No. per hoist	WLL(t)						
				3	5	7.5	10	15	20	
84	M3-088	Socket bolt	2							
85	M3-082	Lever nut	(3)	2	3	2				
	M3-087	U nut	1							
86	M3-018	Guide	(3)					6	8	
87	M3-026	Hook support	2							
88	M3-030	Bottom yoke	1							
89	M3-034	Bottom plate A	(3)					1	2	
90	M3-035	Bottom plate B	1							
91	M3-036	Bottom plate C	1							
92	M3-038	Stay-bolt	4							
93	M3-039	Collar A	2							
94	M3-040	Collar B	4							
95	M3-054	Bottom shaft	1							
96	M2-056	Key plate	2							
97	M3-058	Washer A	2							
98	M3-066	Collar	4							
99	M3-069	Name plate A with rivets	1							
100	M3-083	Socket bolt	4							
101	M3-085	Nut	8							
102	M3-087	Spring washer	4							
103	M3-088	Spring washer	8							
104	M3-091	Tongued washer	4							
105	M3-092	Bolt	4							
⑩	M3-041	Chain pin	1							
⑪	M3-049	Slotted nut	1							
⑫	M3-085	Split pin	1							
	M3-097	Split pin	1							
⑬	M3-800 ⁽¹⁾	Name plate B with rivets	(3)	1	1	1	1	1	2	
⑭	M3-841	Load chain	1							
⑮	M3-842	Hand chain	(3)	1	1	1		1	2	
⑯	M3-931	Warning tag	(3)			1				2
⑰	L4-045	Chain stopper link	(3)			1				2
⑱	M3-045	Stopper assembly	(3)					1		2

Note : (1) When ordering replacement part, use the symbol M3B in place of M3 for 2.5t, 5t and larger types, because there are no interchangeability.

(3) Each number in "WLL" columns is No. per hoist.

ASSEMBLY FOR OVERLOAD LIMITER

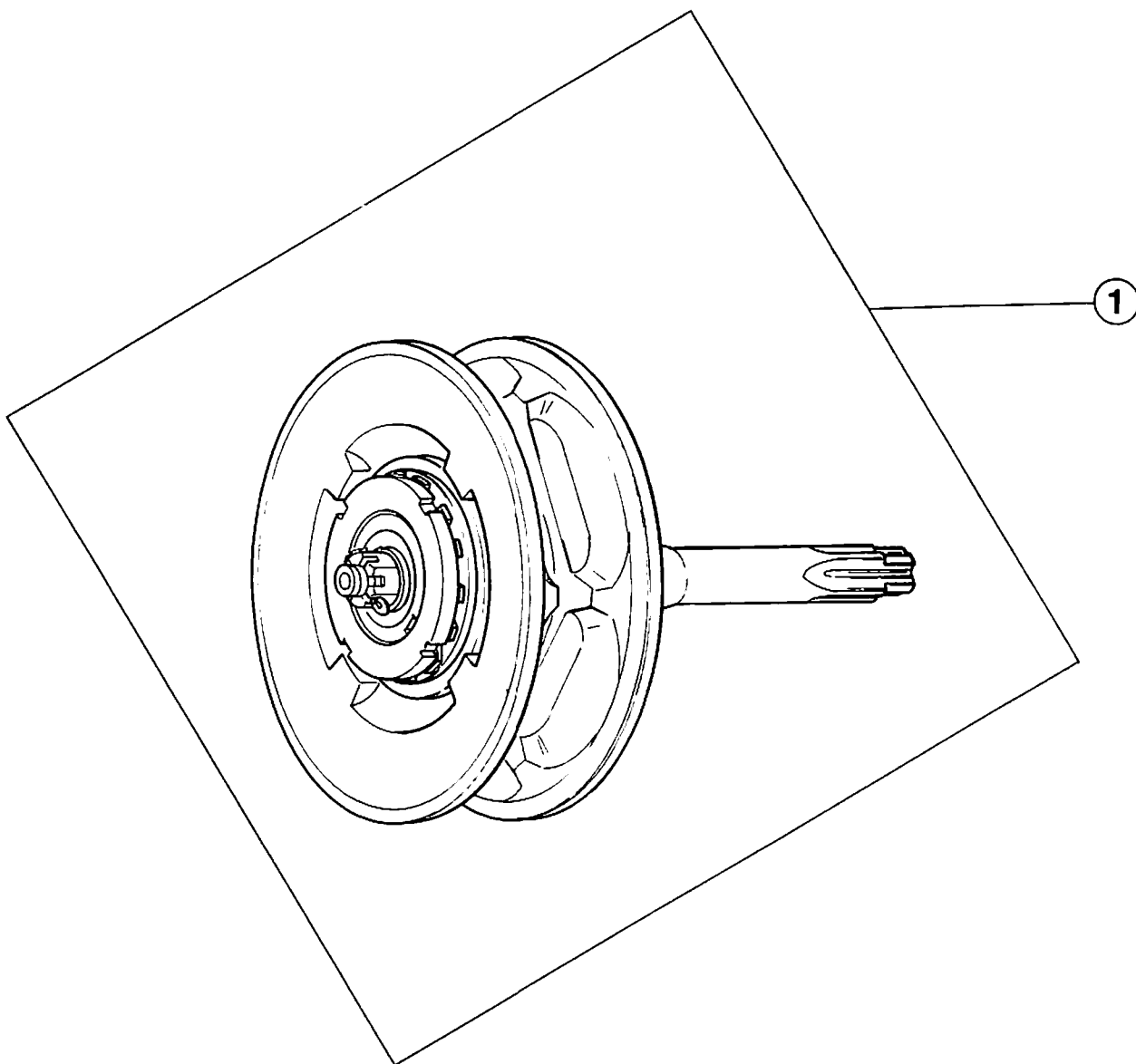

Fig. No.	Part No.	Part name	No. per hoist	WLL(t)				
				0.5	1	1.5 3	2	2.5, 10 5, 15 7.5, 20
①	M3-III A ⁽¹⁾	OLL Kit	1					

Note : (1) When ordering replacement part, use the symbol M3B in place of M3 for 2.5t, 5t and larger types, because there are no interchangeability.

Remark : Every part quantity becomes twice of the number in the column "No. per hoist" for 20t hoist.



KITO CORP.

Tokyo Opera City Tower 16F,
3-20-2 Nishi-Shinjuku, Shinjuku-ku,
Tokyo 163-1416, Japan
Tel. : 03-5371-7341
Fax. : 03-5371-7349
E-mail : overseas@kito.co.jp
URL : <http://www.kito.co.jp>